

LOCHWOOD, P.U.D. PHASE 1

FINAL PLAT
PART OF THE NORTHEAST QUARTER OF SECTION 17 AND
NORTHWEST QUARTER OF SECTION 16, TOWNSHIP 14 NORTH,
RANGE 5 EAST, SALT LAKE BASELINE & MERIDIAN
GARDEN CITY, UTAH

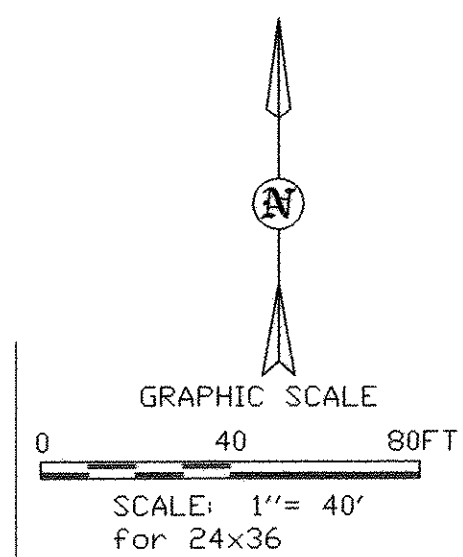

50' radius temp turn-around easement

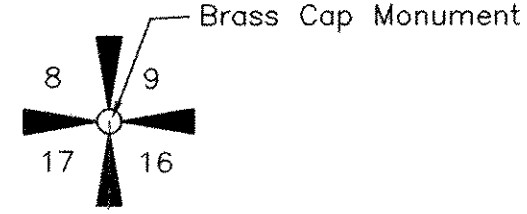

NOTES:

- Setbacks are as follows:
Front: 20 feet
Rear: 20 feet
Side yard: 10 feet total
Street side: 10 feet
- Additional off-street parking for residential: 10
- Area in phase 1: 4.93 acres
Total lots in Phase 1: 20
- Easements for utilities are as follows:
Front: 10 feet
Rear: 10 feet

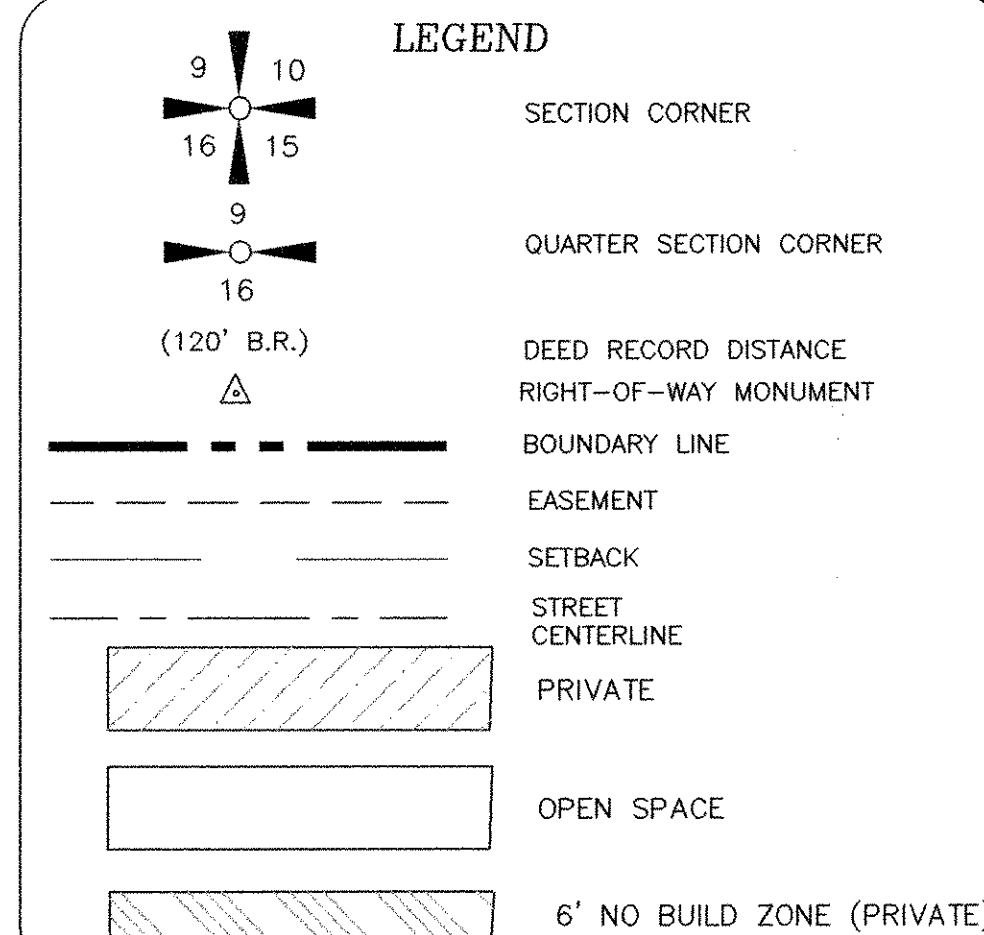

CURVE	LENGTH	RADIUS	DELTA ANGLE	CHORD BEARING	CHORD LENGTH
C1	109.71	1196.30	5°15'16"	S21°27'25"E	109.67
C2	4.87	50.00	5°34'31"	N78°44'25"W	4.86
C3	19.25	20.00	55°09'00"	S5°15'27"E	18.52
C4	10.76	180.00	3°25'25"	S22°39'58"E	10.75
C5	65.83	180.00	20°57'15"	S10°28'38"E	65.46
C6	85.09	200.00	24°22'40"	S12°11'20"E	84.45
C7	19.25	20.00	55°09'00"	N03°11'50"E	18.52
C8	96.26	50.00	110°18'01"	S24°22'40"E	82.07
C9	93.60	220.00	24°22'40"	S12°11'20"E	92.90
C10	19.25	20.00	55°09'00"	N51°57'11"W	18.52
C11	34.91	20.00	100°00'00"	N25°37'20"E	30.64
C12	34.98	180.00	11°08'01"	N81°11'20"E	34.92
C13	9.86	180.00	3°08'23"	N88°19'52"E	9.86
C14	11.65	50.00	13°20'48"	N21°30'43"E	11.62
C15	19.25	20.00	55°09'00"	S03°11'50"W	18.52
C16	2.26	50.00	2°35'12"	N29°28'44"E	2.26
C17	23.20	25.00	5°30'47"	S41°25'13"W	22.37
C18	13.13	50.00	15°03'05"	N66°25'37"W	13.10
C19	23.17	25.00	5°30'50"	S85°26'59"E	22.35
C20	149.17	80.00	106°50'11"	N29°02'25"E	128.48
C21	19.13	220.00	4°58'54"	N87°24'16"E	19.12
C22	35.68	220.00	9°17'30"	N80°16'04"E	35.64
C23	27.93	20.00	80°00'00"	N64°22'40"W	25.71
C24	49.82	200.00	14°16'23"	N82°45'31"E	49.69
C25	118.67	60.00	11°41'23"	N32°45'31"E	100.80
C26	56.10	100.00	32°08'36"	N50°45'04"E	55.37
C27	62.51	100.00	30°05'02"	N19°38'15"E	51.91
C28	50.57	100.00	28°58'25"	N09°53'28"W	50.03
C29	133.56	1216.30	6°17'30"	S20°56'18"E	133.50

LEGAL DESCRIPTION

Part of the Northeast Quarter of Section 17 and the Northwest Quarter of Section 16, Township 14 North, Range 5 East of the Salt Lake Baseline and Meridian, described as follows:
Commencing at the East Quarter Corner of Section 17, Township 14 North, Range 5 East of the Salt Lake Baseline and Meridian monumented with a Brass cap thence N 0°06'52" E 246.34 feet along the section line (Basis of Bearing) to the point of beginning and running thence N 34°22'40" W 31.77 feet; thence N 59°42'51" W 106.18 feet to the south right-of-way of Lochwood Drive; thence along said right-of-way S 33°17'42" W 22.09 feet; thence N 28°17'08" W 57.23 feet to the north right-of-way line of Lochwood Drive; thence along said right-of-way S 89°53'43" W 30.13 feet; thence N 0°06'17" W 53.84 feet; thence N 20°08'06" W 38.49 feet; thence S 89°53'43" W 211.12 feet; thence N 0°06'17" W 90.00 feet to the south right-of-way line of Rendezvous Way; thence along said right-of-way S 89°53'43" W 56.70 feet; thence N 07°08'53" W 40.30 feet to the north right-of-way line of Rendezvous Way; thence N 07°08'53" W 97.13 feet; thence N 89°46'41" E 127.47 feet; thence N 00°01'33" W 215.20 feet; thence N 87°28'25" E 106.39 feet; thence N 80°11'10" E 90.96 feet; thence S 60°47'44" E 47.84 feet to the west right-of-way line of State Highway 89; thence along said right-of-way S 21°27'25" E 109.71 feet; thence S 24°05'44" E 547.23 feet; thence leaving said right-of-way S 75°44'22" W 155.95 feet to the point of beginning, containing 4.93 acres.

BEAR LAKE SPECIAL SEWER DISTRICT APPROVAL
APPROVED THIS 27th DAY OF October, 2006 BY THE BEAR LAKE SPECIAL SEWER DISTRICT
Wald E. Stylian

MAYOR'S APPROVAL AND ACCEPTANCE
PRESENTED TO THE GARDEN CITY MAYOR THIS 16th DAY OF November, A.D. 2006, AT WHICH TIME THIS SUBDIVISION WAS APPROVED AND ACCEPTED.
Walter J. Johnson MAYOR
Kathleen S. Kralop

CITY ENGINEER APPROVAL
APPROVED THIS 12 DAY OF October, 2006 BY THE GARDEN CITY ENGINEER
[Signature]

PLANNING AND ZONING APPROVAL
APPROVED BY THE GARDEN CITY PLANNING AND ZONING COMMISSION THIS 24 DAY OF October, 2006, A.D.
[Signature]

CITY ATTORNEY APPROVAL
APPROVED THIS 15 DAY OF November, 2006 BY THE GARDEN CITY ATTORNEY
[Signature]

SURVEYOR'S CERTIFICATE
I, Brian G. Lyon, a Registered Land Surveyor, hold Certificate No. 275617, as prescribed by the laws of the State of Utah, and do hereby certify that by authority of the owners, I have made a survey of the tract of land shown on this plat, which is accurately described therewith, and have subdivided said tract of land into lots and streets to be hereafter known as Lochwood Phase 1, and that the same has been surveyed and staked on the ground as shown on this plat.

NOTES/NARRATIVE:
1. THE PURPOSE OF THIS SURVEY WAS TO CREATE LOCHWOOD, PHASE 1 A PLANNED UNIT DEVELOPMENT. THE SURVEY WAS REQUESTED BY DENNIS BULLOCK.
2. THE BASIS OF BEARING IS S 0°06'52" W 246.34 FEET BETWEEN NORTHEAST CORNER AND EAST QUARTER CORNER OF SECTION 17.
3. 8"x2" REBAR SET AT ALL PROPERTY CORNERS.
4. THE SOUTH LINE ALONG THE SMITH LINCOLN PROPERTY WAS ESTABLISHED USING A RECORD OF SURVEY BY JSH RECORDED DEC. 22, 1997 UNDER FILING NO. 164 AND FOUND MONUMENTS. THE EAST LINE WAS ESTABLISHED ALONG THE RIGHT-OF-WAY LINE OF STATE HIGHWAY 89. MONUMENTS WERE FOUND AND HELD AT STATIONS 246+08.70 AND 260+17.30. SEVERAL OTHER MONUMENTS FURTHER AWAY FROM THE SUBJECT PROPERTY WERE LOCATED BUT NOT HELD SINCE IT IS IMPOSSIBLE TO MATCH THE RIGHT-OF-WAY PLANS WITH MONUMENTS IN THE FIELD. ALL OTHER LINE ARE INTERIOR TO THE BULLOCK/HARBOR VILLAGE AT BEAR LAKE PARCEL.
5. ALL COMMON AND LIMITED COMMON AREAS ARE CONSIDERED TO BE AN EASEMENT FOR ALL UTILITY, IRRIGATION AND DRAINAGE PURPOSES. THIS INCLUDES THE INGRESS/EGRESS AREA.
6. ALL EXPENSES INVOLVING THE NECESSARY IMPROVEMENTS OR EXTENSIONS FOR A CULINARY WATER SYSTEM, SANITARY SEWER SYSTEM, GAS SERVICE, ELECTRICAL SERVICE, TELEPHONE SERVICE, CABLE TELEVISION SERVICE, GRADING AND LANDSCAPING, STORM DRAINAGE SYSTEMS, CURBS AND GUTTERS, FIRE HYDRANTS, PAVEMENT, SIDEWALKS, SIGNAGE, STREET LIGHTING AND OTHER IMPROVEMENTS SHALL BE PAID FOR BY THE SUBDIVIDER.

OWNERS DEDICATION
Know all by these presents that we the undersigned owners of the above-described tract of land, having caused the same to be subdivided into lots as shown on this plat and name said tract Lochwood PUD Phase 1, and hereby dedicate all roads to the Homeowners Association for private and not public use and hereby dedicate those areas for utility and drainage purposes as shown herein, the same to be used for the installation, maintenance of public utility service lines and drainage as may be authorized by the Homeowners Association. The 20 ft. strip, as identified on the plat, is hereby dedicated to the Town of Garden City, Utah in witness whereof, we have hereunto set our hands this 10 day of Oct, 2006.
Dennis F. Bullock CHAIRMAN
Martha F. Bullock ATTEST
Dennis F. Bullock SECRETARY

INDIVIDUAL ACKNOWLEDGEMENT
STATE OF UTAH }
COUNTY OF CACHE }
ON THE 10th DAY OF October, 2006, PERSONALLY APPEARED BEFORE ME THE SIGNERS OF THE OWNER'S DEDICATION WHO DULY ACKNOWLEDGED TO ME THAT THEY EXECUTED THE SAME.
My commission expires: 10-26-08
Notary Public *Andrea K. Beck*
Residing at: Logan, UT

CORPORATE ACKNOWLEDGEMENT
STATE OF UTAH }
COUNTY OF CACHE }
On the 10th day of October, A.D. 2006, personally appeared before me, Dennis F. Bullock, President of Harbor Village @ Bear Lake Corp., a Utah Corporation, signers of the within instrument who declared to me, that they signed this instrument on behalf of the corporation pursuant to a resolution of the board of directors of said corporation.
My commission expires: 10-26-08
Notary Public *Andrea K. Beck*
Residing at: Logan, UT

COUNTY RECORDER'S CERTIFICATE
STATE OF UTAH }
COUNTY OF RICH }
THIS IS TO CERTIFY THAT THIS PLAT WAS FILED FOR RECORDING IN THE RICH COUNTY RECORDERS OFFICE ON THE 21st DAY OF November, 2006, AT 10:13 a.m. O'CLOCK AND IS DULY RECORDED
FILING NO. 20284
Book H10
Page 1463
Fee \$50.00
John A. Arma
COUNTY RECORDER
COUNTY CLERK

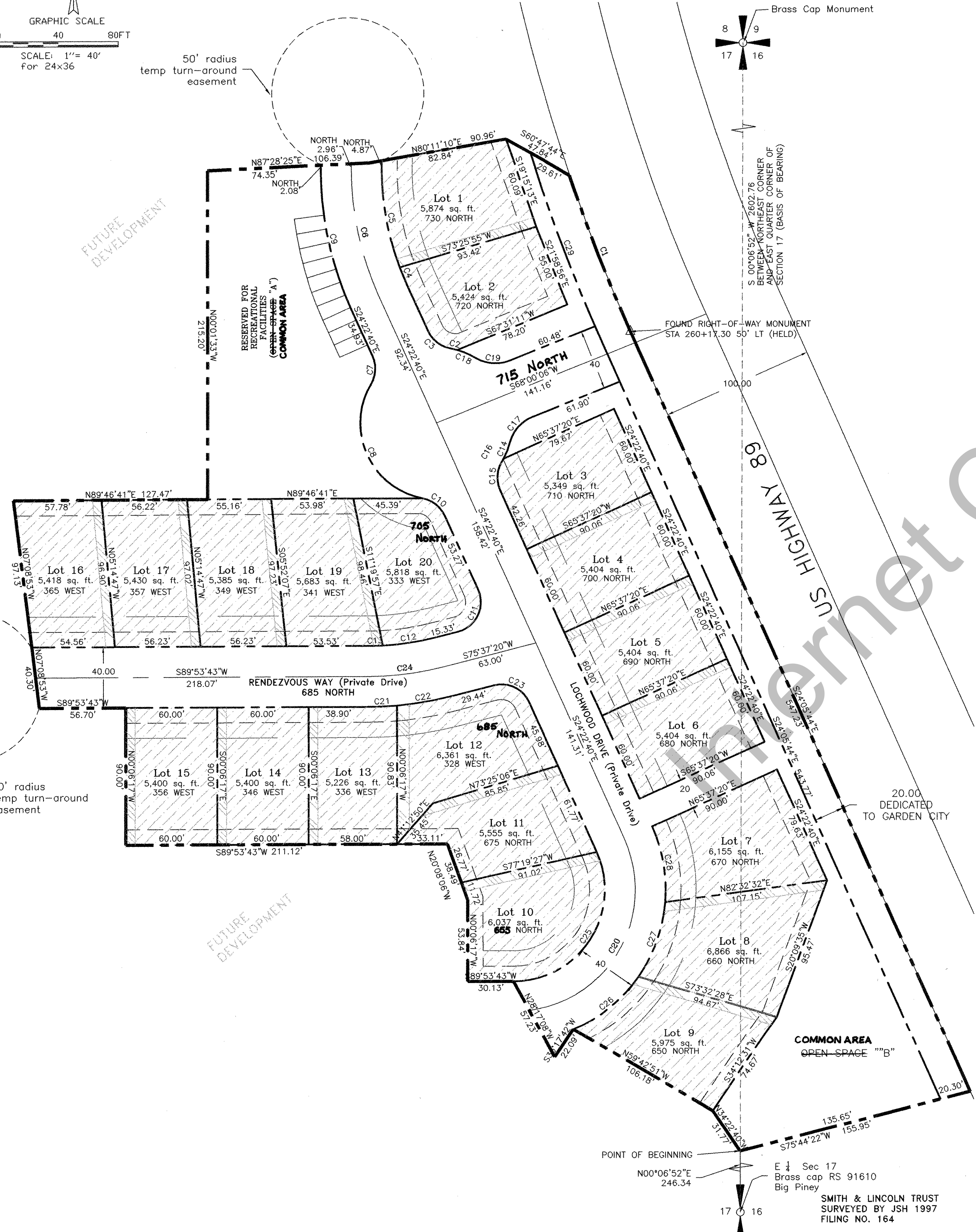

OWNER: HARBOR VILLAGE AT BEAR LAKE CORP. DENNIS BULLOCK 460 E DGB HILL DR. PROVIDENCE, UTAH 84332

PROJECT: LOCHWOOD, P.U.D., PHASE 1

FINAL PLAT

PART OF THE NORTHEAST QUARTER OF SECTION 17 AND NORTHWEST QUARTER OF SECTION 16, TOWNSHIP 14 NORTH, RANGE 5 EAST, SALT LAKE BASELINE & MERIDIAN GARDEN CITY, UTAH

ALLIANCE CONSULTING ENGINEERS
760 WEST 200 NORTH, SUITE 8
LOGAN, UTAH 84321
(435) 755-5121

DATE: 9-20-2006
SCALE: AS NOTED
DRAWING BY: BGL
FINAL: VS-DWG

SHEET 1 OF 1 SHEETS